

Dissertation for:

**The 2017 Young International Freight Forwarder of the Year
Award**

“Diamonds in the Rough” & “A Second Life”



Acknowledgement

I would like to first thank CIFFA for allowing me the opportunity to represent Canada in the 2017 Young Freight Forwarder of the Year Competition.

It has been an amazing learning experience working with not only my colleagues around the world, but CIFFA, and members of the freight forwarding community who started off as complete strangers.

Without all of their help, time, and knowledge, I would not have been able to complete this dissertation.

A special thank you and recognition go out to:

Oswin Paes – Panalpina Projects Division - Canada

Kal Petrov – Panalpina Business Implementation

Willi Tobler – Panalpina Transport Engineering

Andy Young – Tli Cho Transport

Al Fitzgerald – Norex Ice Engineering

Martin Rickenbacher – Panalpina Charter Division

Fred Grootarz – Arco Navigation

Tetsuro Kitabayashi – Panalpina Project Division – Japan

Galina Spivak Panalpina Russia – Projects Team

Executive Summary

Canadian forwarders face many unique challenges when it comes to the transportation of freight. These challenges can range from building a distribution network that must cost effectively supply goods throughout the world's second largest country, all the way to creating a one of a kind supply chain to sustain resource production in the remote wilderness.

It is Canada's geographical size, in conjunction with location of businesses that has the largest effect in how we as a forwarder decide how freight is moved. Businesses operating in bigger cities such as Toronto, Edmonton, and Vancouver have access to a multitude of shipping methods for both import and export points for air and ocean cargo. On the opposite side of the spectrum, there are businesses in remote areas of Northwest Territories which must the ship the bulk of their yearly intake on temporary ice roads. The ice roads are only open for 2-3 months during the year.

The following dissertation will cover the import and export of cargo to two very different geographical areas in Canada:

- Scenario one will cover the challenges of a time sensitive, Exworks move of a mega Earthmover Kamatsu HD785-7 from Ibaraki, Japan to the Diavik Mine site which is located on a manmade island in the Northwest Territories.
- Scenario two will cover an Exworks move of 20 used electric Trollies from Edmonton, Alberta to Samara, Russia requested by the Edmonton local municipality's customer.

Table of Contents

Import Move Introduction.....	6
Import shipment	7
1.1 Mode of transport.....	7
1.2 Equipment Breakdown	7
1.3 Arranging the Charter & Flight Plan	9
1.4 Vehicle Preparation.....	10
1.5 Export Clearance & Documentation	11
1.6 Inland transport	12
1.7 Import documentation and customs clearance.....	14
1.8 Road permits & Stress Analysis	14
1.9 Unloading & Final Delivery	15
1.10 Job Costing.....	17
1.11 Insurance	17
1.12 Conclusion	18
Export Move Introduction	18
Export Shipment.....	19
2.1 Mode of transport.....	19
2.2 Equipment Details & Preparation	19
2.3 Export documentation	20
2.4 Inland transport	21
2.5 Ocean Routing	22
2.6 Import documentation and customs clearance.....	24
2.7 Delivery to Final Destination.....	25
2.8 Job Costing	26
2.9 Conclusion	27
Bibliography and Reference:	28
Appendices:	30

Appendix a 30
Appendix b 31
Appendix c 31
Appendix d 32
Appendix e 32
Appendix f 33
Appendix g 33
Appendix h 34
Appendix i 35
Appendix j 36
Appendix k 36
Appendix l 37
Appendix m 37
Appendix n 37
Appendix o 38
Appendix p 39
Appendix q 39
Appendix r 40

Import Move Introduction

Canada is the world's fourth largest diamond producer, with the Diavik Mine having one of the highest outputs of rough diamonds in the country. With an annual production of 11.6 million carats, valued at US1.6 billion dollars, it is easy to understand why they would invest in setting up an infrastructure over 800 kilometers north of the nearest city, Yellow Knife. Due to high transport costs and aircraft limitations at the site, most of the cargo must wait to be transported until the construction of the ice roads are completed. This takes place during the peak of the Canadian subarctic winter. During these three months, the mines must transport roughly 80 percent of its yearly consumption. This can range from cement used for the making mine walls to Mega machines like the Komatsu Earthmovers.

I have been approached by the Diavik Mines to assist in an expedited move due to production delays at the Kamatsu Ibaraki plant. The Kamatsu 785 is now scheduled to be ready for shipping near the end of the ice road season. If we are unable to move the cargo before the roads become un-operational, the mine site will have to wait until the next winter season to receive the Earthmover. This is not an option for the mine site as reduced mining production will result in lost revenue throughout the year.

Import shipment

1.1 Mode of transport

On Feb 1st, 2017, I was contacted by the Diavik Mines and presented with a cargo ready date of March 15th. Upon receiving the cargo ready date from the customer, my first step is to contact a local Canadian engineering company who specializes in ice road transport. After reviewing statistical data from past seasons, we worked together to set an educated end date of March 31st to have the cargo safely transported over the ice roads. With this data on hand, I approached the customer and advised chartering an aircraft would be the best option due to the size of the freight as well as a limited shipping window.

1.2 Equipment Breakdown

The next step in planning the shipment was to figure out how I would break down the Kamatsu Earthmover. I approached my air charter division with the request of transferring the mechanical drawings to AutoCAD. Once transferred to AutoCAD, I broke down the dump truck into sections. This helps to plan out what aircraft I would use to move the cargo.

- Bucket(See Appendix a)
 - o Dimensions – 9749mm x 5150mm x 2589mm (LxWxH)
 - o Weight – 33.3 metric tons
- 6 Tires with Rims
 - o 2696mm x 745mm (DxW)

- Weight – 1.25 metric tons

- Body(see appendix b)
 - 7768mm x 5410mm x 4178mm (LxWxH)
 - With drivers Cab
 - 7768mm x 5410mm x 2589mm
 - Without drivers cab
 - Weight – 30 metric tons

- Drivers Cab
 - 2680mm x 1720mm x 1598 mm (LxWxH)
 - Weight – 1.5 metric tons

Once I have broken down the truck into its main sections, I begin with the AN124 to see if each piece would fit within the cargo hold. The first complication came when the body would not fit within the cargo hold due to the height of the cab. The second complication came with the bucket. It would not fit without a custom bracket. The bracket is needed to allow the bucket to sit level during transport. There were no issues with weight as the total weight of the cargo is well within the max allowance of 150,000 kilograms.

After reviewing the Earthmover's specifications, I found the cab can be removed at the manufacturing plant prior to transport. I then began working with a local crater to build a custom bracket which would allow the bucket to remain level at a height of 2589mm.

1.3 Arranging the Charter & Flight Plan

Following the confirmation of the aircraft to be used, I began narrowing down the airports that could accommodate the AN124. The three airports I chose as suitable starting points were: Chubu Centrair International Airport, Kansai International Airport, and Narita International Airport. After studying the inland transport options, I found Narita International Airport would not be a viable option due to inland transport regulations requiring the machine to be broken down further for transport. My options were narrowed down to Kansai International and Chubu Centrair International. I started a comparison on costs and shipping timelines from the Ibaraki plant. Subsequently, the decision to utilize Chubu Centrair International was based on the reduced shipping time. The cost difference between the two airports was minimal.

When planning the destination airport my two options were: Yellow Knife Airport and Edmonton International Airport. Between the two airports, Yellow Knife is the closest to the mines, with a total distance of 400 kilometers. Yellow Knife has a runway length of 2,287 meters. It covers the 900 meters needed for a fully loaded AN124 to land, but due to weight limitations at Yellow Knife Airport, the maximum allowable cargo weight the AN124 can land with is 45 metric tons. The cargo load we need to fly in is 72 metric tons. Therefore, Yellowknife is voided for use as an option for this move.

This confirms Edmonton International Airport as the destination airport. I began working with my charter team to prepare the contract process with the Diavik Mines. It is

important to begin the process of arranging the charter well in advance to allow adequate time for positioning of the aircraft and applying for landing rights

The flight time from Chubu Centrair International to Edmonton International airport is approximately 14 hours.

1.4 Vehicle Preparation

I began the process of preparing the vehicle for transport, after we figured out how the vehicle needed to be broken down. There are three sections that need preparation for transport:

- Body & Cab
 - o The tires must be removed and additional blocking added in place of the tires.
 - o The cab roof needs to be removed in the facility and palletized for transport.
- Bucket
 - o A bracket needs to be custom made to allow the bucket to maintain position while in transport(see appendix c)

These preparations will be communicated and organized with the customer, a 3rd party fabricator, and the Komatsu Plant. In addition to the dismantling of the Komatsu Earthmover the following vehicle preparations need to be enforced to ensure compliance with the IATA Dangerous Goods Regulations Guide 2015(see appendix d):

- UN3166 – Class 9 – Packing Instructions 950 for cargo aircraft only

- (A) The fuel tank should be drained as far as practicable – If fuel remains, it must allow for expansion in the tank.
- (C) Batteries must be securely fastened and protected in such a manner to protect against damage and short circuits.
- (D) Dangerous goods required for the operation or safety of the vehicle such as “fire extinguishers” and safety devices must be securely mounted in the vehicles.
- (D.2) Theft protection devices, installed radio communication or navigation systems must be disabled.
- All involved state limitations and operator variations must be checked to ensure compliance.

Once I have confirmed the preparations have been completed by all parties, I move forward with our office overseas to begin preparing documentation and arranging the inland transport.

1.5 Export Clearance & Documentation

Export clearance in the case of a charter differs slightly from general cargo in the sense that my team will be working with Japanese customs to prepare the following documentation 2-3 weeks in advance of the shipment:

- Export Declaration (Customs form C-5010) which includes

- Code, number, name, quantity and price of goods;
 - Destination of cargo and name or appellation and address or place of residence of consignor
 - Name and registration number of the carrier (vessel or aircraft) of the cargo;
 - Location of the storage of goods
- Commercial invoice
 - Packing list
 - Manufacturer issued literature including cargo specifications and function

Arranging this in advance will allow the cargo to bypass the normal inspection procedures which require the cargo to be brought into a registered customs facility known as a Hozie for inspection prior to export.

1.6 Inland transport

Prior to transport I have arranged for the following ahead of schedule:

- 2 120 metric ton Cranes (see appendix e)
- 4 53-foot drop deck trailers
- 4 53-foot flatbed trailers
- Local Shipping Barge(see appendix f)

Typically, inland transport for oversized equipment by truck is more difficult in Japan than in North America. This is due to required permits and size limitations on the

roadways. However, the Ibaraki Plant is located adjacent to the Ibaraki Port and there is a well-established transport road that leads directly from the plant to the port.

When the cargo is ready, the Ibaraki Plant will use internal cranes within the facility, to load the trucks body and bucket on to a 53-foot multi-axel drop deck trailer. It will be securely fastened to the trailer using chains at approved lashing points. The tires and cab will be securely fastened using webbing and nylon straps to a 53-foot flatbed then trucked to port. The total distance from plant to port is roughly 1.5 kilometers.

Once the cargo reaches port, it will be lifted by a 120 metric ton crane onto a local transport barge according to the preapproved load plan (Appendix g). The transportation from the Port of Ibaraki to the Chubu Centrair International Airport (NGO) will be approximately 1.5 days, barring any unforeseen weather conditions. The second crane will be arranged to unload the vessel, after the barge has arrived at Chubu Centrair International Airport. The same trucking equipment will be arranged to transport the cargo from the port, which is located 2 kilometers from the designated handling facility in NGO airport.

It is important to note that in order to limit our liability as a forwarder, the responsibility of the load planning and securing of the cargo, should be arranged by the appointed crew loading the aircraft. Loading will take place by having the cargo lifted onto ULD's, towed into place and secured for transport (see appendix h).

The total transit time from the Ibaraki Plant to the complete loading of the AN124 is approximately 3 days.

1.7 Import documentation and customs clearance

In 2017, the third phase of the Advance Commercial Information (ACI) initiative called eManifest went live for Canada. eManifest requires all carriers, freight forwarders and importers to send commercial information about their shipments, in advance, electronically to the Canada Border Services Agency (CBSA) . This information will include cargo details, conveyance, house air waybill, and importer data. This data must be submitted prior to the arrival of the AN124 at Edmonton International Airport.

In addition to eManifest the commercial invoice, packing list, and House Air Waybill should be collected to complete the following documentation for submission to CBSA for customs clearance:

- Canada Customs Invoice Form
- B3 Customs Coding Form
- Cargo Control Document

1.8 Road permits & Stress Analysis

To work out the permits, I broke down the road transportation into two groups:

- Northwest Territories ice roads
- Interprovincial Roadway transport.

To start, I needed to find out if the combined weight, height, or width would require over dimensional or overweight permits. To do this, I reviewed the Heavy Truck Weight and

Dimension Limits for Interprovincial Operations in Canada. It provided the required information for both Alberta and the Northwest Territories.

Following the provincial regulations both the bucket and body require over dimensional permits and placarding due to it's the width. Each tractor trailer will also require a lead car to escort the freight from Edmonton International airport until arrival at the Diavik Mine site. The permitting, trucking, and lead car will be arranged through Tli Cho transport.

The second area of focus was the trucking requirements for transporting the equipment on the ice road. To better understand the requirements, I contacted Norex Ice Engineering. I found that unlike asphalt, the requirements measured are not the weight per axel, but rather axle spacing, and axle group loading for the fully loaded unit. To run their stress analysis, I submitted cargo schematics, loading plan, in conjunction with the tractor trailer equipment used for transport (see appendix i). Based on the submitted material the engineering company cleared the cargo for transport up to March 31st, 2017.

1.9 Unloading & Final Delivery

Prior to the landing of the AN124 at Edmonton International Airport, I arranged for the following equipment with Tli Cho Transport to safely transport the Kamatsu Earthmover to the Diavik Mine site:

- 2 Tri-axel tractor trailers equipped with a tri-axel Jeep and a 53-foot low-profile gooseneck trailer (see appendix i)
- 2 53-foot flatbed trailers.

- 120 metric ton mobile crane (see appendix e)

When the cargo arrives, it will be customs cleared, unloaded by crane, and securely fastened with chains to the approved trucking equipment. I chose Tli Cho Transport as the trucking company because of their experience with ice road transportation. They employ skilled drivers who have accrued years of ice road driving experience delivering anything from over dimensional cargo to mines to supplies for small towns in the Northwest Territories.

The total distance from Edmonton Airport to the Diavik Mines is 1850 kilometers. The transport time is roughly 32-35 hours and will require team drivers to complete the delivery within two days. The first leg of transport to the Diavik Mines is from Edmonton Airport to Yellow Knife, approximately 1500 kilometers. During the trip, the drivers will be escorted by a lead car to Yellow Knife, where they will stop for rest, refuel, and inspect the cargo for the final leg of the delivery.

When the inspection is completed, the loads will begin their 16-20 hour, 350 kilometers trip to the Diavik mines. During the final leg of transport, the drivers will face heavy traffic, limited daylight, and possible road closers due to warmer weather. The delivery time is extended due to heavy traffic, as well as an enforced speed limit of 25 kilometers when traveling on open ice and 10 kilometers when approaching the shore. If the speed limit is not strictly adhered, to the increased speed can create waves underneath the ice which can cause blowouts. If a blowout occurs, the tractor trailer can fall through, become submerged in the ice, causing loss of equipment and possible injuries or death to the driver. (see appendix j). Upon arrival to the mine site, each piece of the cargo will

be unloaded by cranes inside the mines maintenance facility and reassembled under the watchful eye of the Kamatsu Project Engineer.

Total transport time from Edmonton International Airport to the Diavik Mines is 2 days.

1.10 Job Costing

Origin Charges		Curr.	Minimum	Rate
Origin Charges	Trucking From Plant to Port of Ibaraki	USD		\$ 13,000.00
	Crane at port of Ibaraki	USD		\$ 10,000.00
	Barge from Ibaraki to NGO Airport	USD		\$ 55,000.00
	Crane at NGO Airport	USD		\$ 13,000.00
	Trucking from to Cargo Facility NGO	USD		\$ 10,000.00
	Bcustom Bracket	USD		\$ 5,000.00
From	To	Curr.	Flate fee	
Chubu Centrair International	Edmonton International Airport	USD		\$ 762,000.00
Destination Charges		Curr.		Rate
Destination	Crane fee - Edmonton International Airport	USD		\$ 13,000.00
	Delivery from Edmonton Airport to Mine Site	USD		\$ 60,000.00
	Pilot Cars	USD		\$ 6,500.00
	Total Cost			\$ 947,500.00
	Cargo Value			\$ 1,500,000.00
	Insurance at Value \$2,686,750.00		.33 USD per \$100	\$ 8,884.27
	Total Cost			\$ 956,384.27

1.11 Insurance

Throughout the planning process, we have taken extraordinary measures to mitigate the possible risk and damage to the Kamatsu Earthmover. However, we are aware there is never a 100 percent guarantee of no risk or damage while transporting large and heavy cargo, such as the Earthmover. In accordance with the Montreal Convention, air carriers are only liable for damages up to 100,000 SDR. The Kamatsu Earthmover has a value of 1 million US Dollars. Should the Earthmover sustain critical damage, the maximum

liability from the air carrier would not begin to cover the financial loss incurred by the consignee. Therefore, it is our recommendation the consignee insures the Earthmover.

1.12 Conclusion

When approached by the Diavik Mines, I was faced with a multitude of challenges. The challenges ranged from disassembling the Kamatsu Earthmover to fit within the AN124 to maximizing our time restraints in order to beat the end of the ice road season. When given a 15 day window to safely move the Earthmover from the Ibaraki Plant in Japan to the Diavik Mine site in the Northwest Territories of Canada, we were able to together a solution for door to door service with a transit time of approximately 5-6 days. The reduced transit time has will mitigate the risk of the cargo missing the shipping window cargo as it will arrive well in advance of the end of the ice road season. This will ensure the Diavik Mine site can run at full production during 2017 year.

Export Move Introduction

Every year local Canadian Municipalities upgrade their equipment, vehicles, and infrastructure. Governments will typically try to sell off the decommissioned equipment to recoup funds that will go into new investment. The older equipment may be sold and shipped domestically or sold internationally to private customers or other government municipalities.

The City of Edmonton, Alberta has recently decommissioned their electric trolley buses as their new order from a local supplier has been completed. A Russian buyer has

purchased 20 of the decommissioned trolley buses and wants to ship them from Edmonton, Alberta to Samara, Russia. We have been approached by the City of Edmonton to find a transport solution, for their buyer to economically move the 20 trolley buses. Their transport ready date is spring 2017.

Export Shipment

2.1 Mode of transport

The mode of transport for this shipment will be ocean freight. While air is an option, it does not fit in this particular case as the buyer is trying to minimize costs and has not presented a set deadline that is unachievable by ocean.

There are two types of vessels that are typically used to transport cargo of this nature. The first is a break-bulk vessel. It operates by loading the cargo with cranes that are attached to the vessel into various holds which can be manipulated to accommodate many kinds of non-containerized freight. The second is called a roll on roll off vessel. The vehicles are either driven or loaded onto Mafis' (see appendix k) and then towed up the vessels ramp and stowed within.

2.2 Equipment Details & Preparation

20 Electric Trolley Busses

- Weight - 12,500 metric tons
- 40-foot x 121 inches x 102 inches (L x W x H)
- No engine or power source

20 Electric Arms

- Weight 75 kilograms
- 3 inches x 180 inches' (D x L)

Vehicle preparation

- The electrical arms should be safely secured within the buses in such a manner that they will remain in place during the shipping process.
- If there is a gear box it should be positioned in park during each leg of transport.

2.3 Export documentation

Before the cargo departs Edmonton, Alberta the following documentation should be submitted to Canadian and US customs:

- Export Declaration (B13A) should be completed and submitted to Canadian Customs.
- A transportation and exportation entry (T&E) must be submitted to US Customs prior to the trollies crossing the border. This entry will allow the cargo to be transported through the US without paying any duties or taxes.

For ocean transport, the following documentation should be collected and sent to the steamship line a minimum of 5 days prior to the departure of the vessel:

- Original Title
- Lien Release
- 5 copies of a Lien Release

- 5 copies front and back of the title
- 5 Copies of the dock receipt

2.4 Inland transport

There are two main modes of transportation to the desired port of export that I examined. First is the transportation by rail and the second is transportation by truck. In the (appendix I), you will find approximate quotations received for both rail and truck options for several of the ports I took into consideration. In combination with the ocean freight rates, I found that the most cost effective options for transportation are by truck to Houston or Baltimore. Trucking is a more viable option because the trollies are neither oversized nor overweight and can be moved on standard equipment without the need for special permissions.

Rail becomes expensive due to the many additional costs incurred including:

- The need to truck the cargo to the rail terminal
- Hiring cranes to discharge and load the cargo into the rail car
- An additional crane to load the buses to the truck for delivery to terminal.
- Management costs and engineering drawings that are required to meet transportation regulations.

The shipper will be responsible for the preparation of the buses prior to transport. The transportation from Edmonton, Alberta to Baltimore, Maryland or Houston, Texas will be

done on a 53-foot drop deck trailer with a sliding rear axle (see appendix m). The buses will be loaded using ramps and winched into position on to the bed of the truck. Once in position, the wheels should be chocked with blocks, the buses fastened for transport, and the gears put into a parked or locked setting.

The trucking to terminal will require no special permits as neither the width nor combined height of the buses and trailer exceed road limitations set within the Canada or the United States. The transportation time to either port is 6 days and is roughly 3700-3800 kilometers (see appendix n). Each truck will move under a T&E bond with individual commercial invoice to allow the buses to move independently. This would help to avoid delays should inspections be required. Once the buses have arrived at the respective terminals, they will either be unloaded by crane onto Mafis' in Baltimore or placed directly in a cargo holding area to be towed onto the vessel in Houston.

2.5 Ocean Routing

After sourcing ocean freight costs from Halifax, Tacoma, Houston and Baltimore I identified two cost effective routings. The first is from the Port of Baltimore, Maryland to St. Petersburg, Russia. The second is from the Port of Houston, Texas to Novorossiysk, Russia. Both routings will utilize a roll on roll off vessel or more commonly known as a RORO vessel (see appendix o). As the move does not stipulate a mandatory time of arrival, I will present two separate options to the customer. The first option is by RORO vessel from Houston Texas to Novorossiysk, Russia. The advantage in this option is a cost reduction of roughly 4% when compared to the transport costs from Baltimore. The

second option is by RORO vessel from Baltimore, Maryland to St. Petersburg Russia. The advantage of utilizing the Baltimore routing is the reduced transit time of 11 days. Both options will utilize RORO vessels for the transportation of the trolley buses to the port of destination.

Routing option #1: Baltimore, Maryland to St. Petersburg, Russia

Once the cargo has arrived by truck at the Port of Baltimore the buses will be lifted by crane and fastened with chains, either crosswise, or by lashing points or by suspension onto the Mafis' provided by the line. Once secured, the buses will then be towed into the cargo hold and further secured with 10+ web lashings to the ships hold in accordance with SOLAS chapter VI and VII & the Code of Safe Practice for Cargo Stowage and Securing (see appendix p). These guidelines are in place to avoid potential hazards to both the crew and ship as well as preventing damage to the cargo. During transport, it is common for vessels to experience roughly 22 degrees of rolling. This can increase up to 35 degrees in heavy seas (see appendix q).

The routing from Baltimore, Maryland to St. Petersburg is: Baltimore – Bremerhaven - St. Petersburg with a transshipment occurring in Bremerhaven. When the cargo arrives at Bremerhaven, it will be towed off and loaded to a smaller RORO vessel. The cargo will be secured in the same manner as the main voyage. The cargo will then be transported for final delivery to St. Petersburg. The total transit time from Door Edmonton to Port St. Petersburg is approximately 25 days.

Routing Option #2: Houston, Texas to Novorossiysk, Russia

At the port of Houston, the buses will be unloaded by crane into the yard and will remain there until time of loading. This specific line does not utilize Mafi trailers, so they will be towed into place and loaded as break bulk. The securing of the cargo will be done in accordance to SOLAS chapter VI and VII & the Code of Safe Practice for Cargo Stowage and Securing as noted in option one. The routing from Houston, Texas is Houston – Istanbul – Novorossiysk. It is important to note this routing is direct and there is no transshipment reducing the possibility of damage or delays. Total transit time from door Edmonton, Alberta to Novorossiysk, Russia is 36 days.

2.6 Import documentation and customs clearance

Before the cargo arrives at port, I have instructed our St. Petersburg office to establish a contract to customs clear the cargo on behalf of the consignee.

For clearance, I have sent the following documentation:

- Bill of Sale
- Vehicle Title (if applicable)
- Commercial Invoices
- Packing List
- Bill of Lading
- Certificate of conformity

2.7 Delivery to Final Destination

Once the cargo has reached either St. Petersburg or Novorossiysk, there are two viable options for the inland transport. The first is transporting the buses by truck and the second is the utilizing rail transport. I did also explore the possibility of barging or using the commodity transport ships as a third mode of transport directly to the port of Samara. However, using the Volga River was deemed not feasible due to higher transportation costs than trucking or rail. Trucking will provide the most cost effective and fastest transit time. However, both options should be considered; should there be issues with equipment availability at port.

Trucking from Novorossiysk & St. Petersburg to Samara:

Once the cargo has reached either port, it will be customs cleared and loaded by crane onto a Scania or Volvo + 3-axle step deck semi-trailer. Once loaded, the bus tires will be chocked and secured by the suspension to the trailer. The height and weight are within local regulations, but the width classifies the cargo as oversize. It exceeds 2.55 meters. Preliminary routings should be developed and submitted for permission issuance by RosAvtoDor. The total transport time and distance are roughly the same from either port 3-5 days and 1800-1900 kilometers (see appendix r).

Rail from Novorossiysk & St. Petersburg to Samara:

Once the cargo has reached either St. Petersburg or Novorossiysk it will be customs cleared and loaded by crane onto 53-foot step deck trailer to be transported to the rail yard. Upon arrival to the rail yard, the buses will then be loaded by crane onto Standard 60 – 68 metric tons, 4-axle flat railcar, equipped with welded steel frame and wooden-metallic or wooden floor. Prior to loading onto the railcars, a loading and lashing scheme should be worked out and approved by railway authorities. This is to ensure safe transportation to destination. The total cost, transport time, and distance are roughly the same from either port at 6-8 days and 1800-1900 kilometers.

2.8 Job Costing

Description of charges		Currency	
Origin	Pick up Edmonton	USD	\$4,800.00 Per Bus
	Current fuel surcharge (subject to fluctuation)	USD	Included
	Export Documentation Fee (code 0600)	USD	\$25.00 Per B/L
	Crane Fee - Per 5 hours	USD	\$2,500.00 Based on approximalty 10 hours load time
	Export Declaration - B13 (includes 3 HS codes)	USD	\$35.00 Per B-13
	Total:		\$98,560 USD
From	To	Currency	Ocean Freight Rate
Baltimore	St. Petersburg		
Cargo Description:	20 x Buses – Static Cargo	USD	\$72.00 Per W/M
Cargo Dimensions:	480x102x121 Inches		
Cargo Weight:	12,500 kg per bus	Total:	\$139,795 USD
CBM:	97.08 CBM per bus		
From	To	Currency	
BAF - Bunker Adjustment Factor		USD	\$2.33 Per W/M
CAF - Currency Adjustment Factor		USD	Included
LSF - Low Sulphur Fee (code 1900)		USD	Included
Origin Terminal Handling charges		USD	\$3,750.00
Total			\$8,273 USD
From	To	Currency	
Destination Terminal Handling charges		USD	Included
Import Handling Fee		USD	Included
Delivery from St. Petersburg to door Samara, Russia		USD	\$3,148.00 Per Bus
Current fuel surcharge (subject to fluctuation)		USD	Included
loading by crane		USD	\$150.00 Per Bus
customs clearance		USD	\$45.00 Per B/L
delivery from port to dispatch area		USD	\$126.00 Per Bus
Port Forwarding		USD	\$100.00 Per Bus
Total			\$70,480 USD

\$788,818 total insured value CIF to door Samara at .12 usd per \$100.00: 946.58 USD

Total cost for door to door transport from Edmonton, Alberta to Samara, Russia is \$318,054.58 USD

FRC / BAF / CAF / GRI / PSS are subject to fluctuation.

Subject to space & equipment availability.

Transit times are approximate and are subject to change. Approx.

Legalization, certification and courier fees (if any required) as per outlay.

2.9 Conclusion

When comparing the two separate routings each one has its own distinct advantage. The Baltimore service to Samara Russia offers a reduced transit time of 11 days and the Houston service to Samara offers a cost reduction of 4%. However, after creating a risk analysis, I found there are further operational advantages for routing the cargo through St. Petersburg over Novorossiysk. I focused on two areas when creating the risk analysis: port infrastructure and final delivery to Samara, Russia.

The port infrastructure for Novorossiysk and St. Petersburg is where I begin to see notable differences in operations and experience in handling cargo of this nature. Container terminals at Novorossiysk are smaller and new capacity additions are required to improve throughput of cargo. Congested road and railway traffic, tough weather conditions in the Black Sea Basin, are all factors for hindering growth in the region. St. Petersburg is the largest port within Russia and moves roughly three times the volume of Novorossiysk on a yearly basis. With further developed infrastructure and dedicated terminals for RORO vessels, there is a reduced chance for delays and accidents that could affect the timely delivery of the buses. Larger volumes coming through the Port of St. Petersburg, means there is a larger amount of available road and rail equipment available for use; therefore also reducing the possibility of delays once the cargo has been discharged from port.

In my professional opinion the overall cost savings for routing the cargo through Novorossiysk is negated by the extended transit time and the possibility of disruptions that could occur at port. The disruptions can stem from the lack of infrastructure, handling experience, and possible equipment shortages. The routing presented and arranged for the customer should be: Pre-carriage arranged on truck through the USA on a T&E bond to the port of Baltimore for export to St. Petersburg Russia. The buses will then be loaded onto RORO vessels for transport to Bremerhaven and transhipped to the Port of St. Petersburg. Customs clearance should be arranged at port. After the buses are customs cleared, they are to be transported by truck from St. Petersburg to Samara, Russia for final delivery.

Bibliography and Reference:

- Aerospace Logistics | Helicopter Shipping | Jet Engine Transport. (2017). *Over Dimensional Freight Transport*. [online] Available at: <http://imtbc.com/over-dimensional-freight-transport/> [Accessed 17 Feb. 2017].
- Airforce Technology. (2017). *An-124 Ruslan (Condor) Large Cargo Aircraft*. [online] Available at: <http://www.airforce-technology.com/projects/an124/> [Accessed 4 Mar. 2017].
- Anon, (2017). [online] Available at: <http://www.comt.ca/english/programs/trucking/MOU%202014.pdf> [Accessed 13 Apr. 2017].
- Cbsa-asfc.gc.ca. (2017). *eManifest*. [online] Available at: <http://www.cbsa-asfc.gc.ca/prog/manif/menu-eng.html> [Accessed 15 Apr. 2017].

- Dot.gov.nt.ca. (2017). *Winter Roads*. [online] Available at: <http://www.dot.gov.nt.ca/Highways/Winter-Roads> [Accessed 15 Feb. 2017].
- En.wikipedia.org. (2017). *Yellowknife Airport*. [online] Available at: https://en.wikipedia.org/wiki/Yellowknife_Airport [Accessed 11 Mar. 2017].
- Fitzgerald, A. (2017). *Yiffa - Brad Davis*. [email].
- Globalports.com. (2017). *Key Russian gateways | Global Ports*. [online] Available at: <http://www.globalports.com/globalports/about-us/our-industry-overview/container-market/key-russian-gateways> [Accessed 23 Feb. 2017].
- Imo.org. (2017). *Home*. [online] Available at: <http://www.imo.org/en/OurWork/Safety/Cargoes/CargoSecuring/Pages/default.aspx> [Accessed 15 Mar. 2017].
- Kitabayashi, T. (2017). *Young Freight Forwarder of the year*. [email].
- Paes, O. (2017). *RATE QUOTE FROM HOUSTON, TX TO NOVOROSIYSK, RUSSIA*. [email].
- Rickenbacher, M. (2017). *Drawing for AN124 Load*. [email].
- Spivak, G. (2017). *Panalpina Canada- YIFFA Competition*. [email].
- tkanchenko, D. (2017). *Panalpina Canada - YIFFA Competition*. [email].
- Tobler, W. (2017). *PDF Shots*. [email].

- Uscustomsclearing.com. (2017). *IE, TE, IT, Immediate Exportation, Transportation and Exportation*. [online] Available at: <http://www.uscustomsclearing.com/glossaryieandit.html> [Accessed 1 Mar. 2017].
- Young, A. (2017). *YIFFA - Brad Davis*. [email].

Appendices:

Appendix a

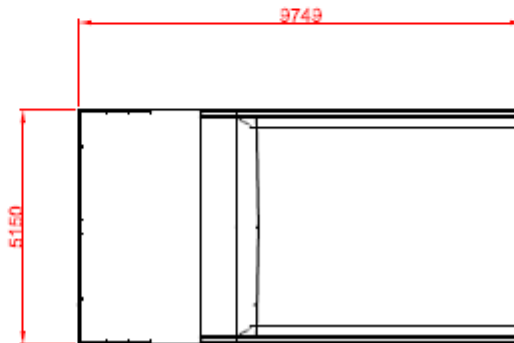
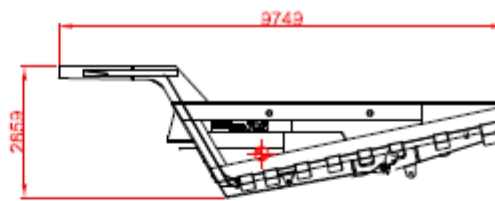
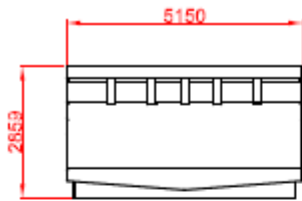

Appendix b

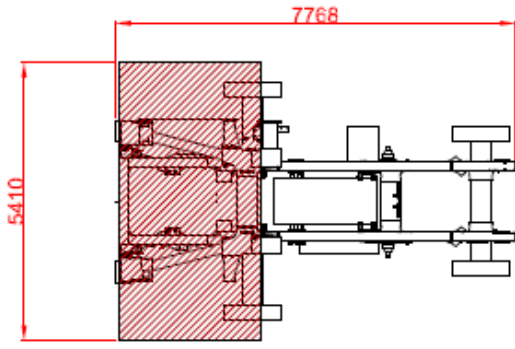
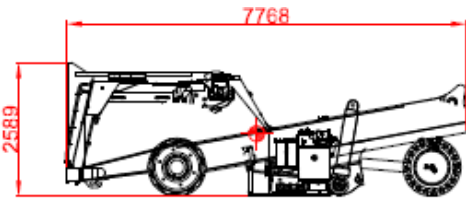
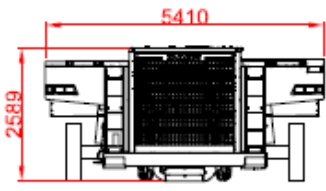

Appendix c

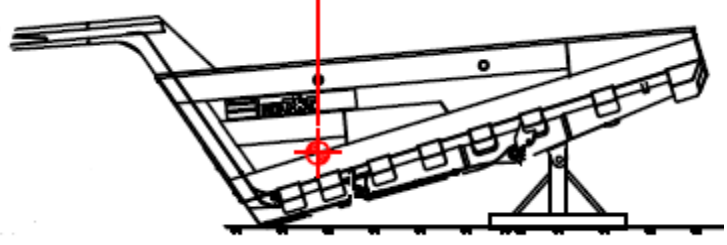

Appendix d



5.9 Packing Instructions—Class 9—Miscellaneous Dangerous Goods

PACKING INSTRUCTION 950

OPERATOR VARIATIONS: AC-04/05, AM-09, AS-05, KE-06, ME-04, MH-12

This instruction applies to UN 3166 **Engine, internal combustion, flammable liquid powered, Engine, fuel cell, flammable liquid powered, Vehicle, flammable liquid powered** and **Vehicle, fuel cell, flammable liquid powered** on passenger aircraft and Cargo Aircraft Only (see PI 951 for **Engine, internal combustion, flammable gas powered, Engine, fuel cell, flammable gas powered, Vehicle, flammable gas powered** and **Vehicle, fuel cell, flammable gas powered**).

Vehicles, machines or equipment containing internal combustion engines or fuel cell engines powered by a flammable liquid must meet the following requirements:

- (a) **Flammable liquid fuel tanks.** Except as otherwise provided for in this Packing Instruction, fuel tanks must be drained of fuel and tank caps fitted securely. Special precautions are necessary to ensure complete drainage of the fuel system of vehicles, machines or equipment incorporating internal combustion engines, such as lawn mowers, outboard motors, etc., where such machines or equipment could possibly be handled in other than an upright position. When it is not possible to handle in other than an upright position, vehicles, except those with diesel engines, must be drained of fuel as far as practicable and if any fuel remains it must not exceed one quarter of the tank capacity.
- (b) **Diesel engines.** Vehicles equipped with diesel engines are exempted from the requirement to drain the fuel tanks, provided that a sufficient ullage space has been left inside the tank to allow fuel expansion without leakage, and the tank caps are tightly closed. A careful check must be made to ensure there are no fuel leakages.
- (c) **Batteries.** All batteries must be installed and securely fastened in the battery holder of the vehicle, machinery or equipment and be protected in such a manner as to prevent damage and short circuits. In addition:
 1. if spillable batteries are installed, and it is possible for the vehicle, machine or equipment to be handled in such a way that batteries would not remain in their intended orientation, they must be removed and packed according to Packing Instruction 492 or 870, as applicable;
 2. if lithium batteries are installed, they must be of a type that has successfully passed the tests specified in the *UN Manual of Tests and Criteria, Part III, subsection 38.3*, unless otherwise approved by the appropriate national authority of the State of origin, must be securely fastened in the vehicle, machinery or equipment and must be protected in such a manner as to prevent damage and short circuits;
 3. if sodium batteries are installed they must conform to the requirements of Special Provision A94.
- (d) **Other operational equipment.**
 1. dangerous goods required for the operation of the vehicle, machine or equipment, such as fire extinguishers, tire inflation canisters, safety devices, etc., must be securely mounted in the vehicle, machine or equipment. Aircraft may also contain other articles and substances which would otherwise be classified as dangerous goods but which are installed in that aircraft in accordance with the pertinent airworthiness requirements and operating regulations. If fitted, life-rafts, emergency escape slides and other inflation devices must be protected such that they cannot be activated accidentally. Vehicles containing dangerous goods identified in Subsection 4.2—List of Dangerous Goods as forbidden on passenger aircraft may only be transported on cargo aircraft;
 2. vehicles equipped with theft-protection devices, installed radio communications equipment or navigational system must have such devices, equipment or system disabled.

Note:
Replacements for the dangerous goods permitted in paragraphs (c) and (d) must not be carried under this packing instruction.

Internal combustion or fuel cell engines shipped separately (not installed)

When internal combustion engines or fuel cell engines are being shipped separately, all fuel, coolant or hydraulic systems remaining in or on the engine must be drained as far as practicable and all disconnected fluid pipes must be sealed with leak-proof caps, which are positively retained.

This requirement also applies to vehicles, machines or equipment containing internal combustion engines or fuel cell engines that are being shipped in a dismantled state such that fuel lines have been disconnected.

Appendix e



Appendix f

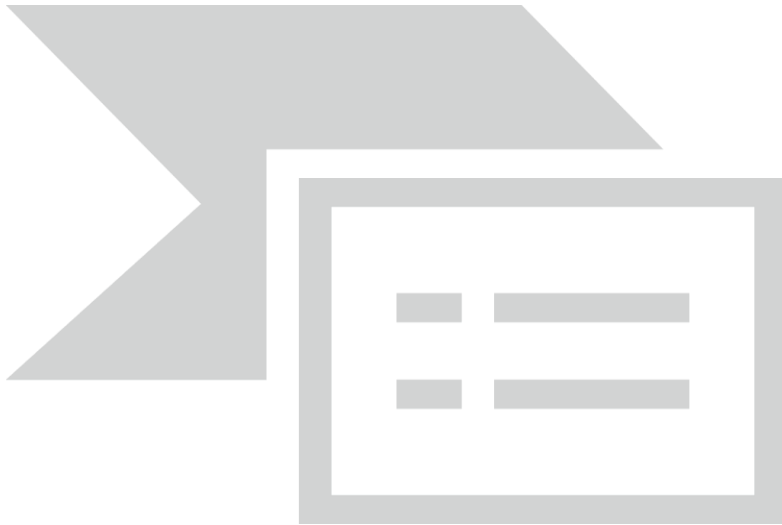

Appendix g

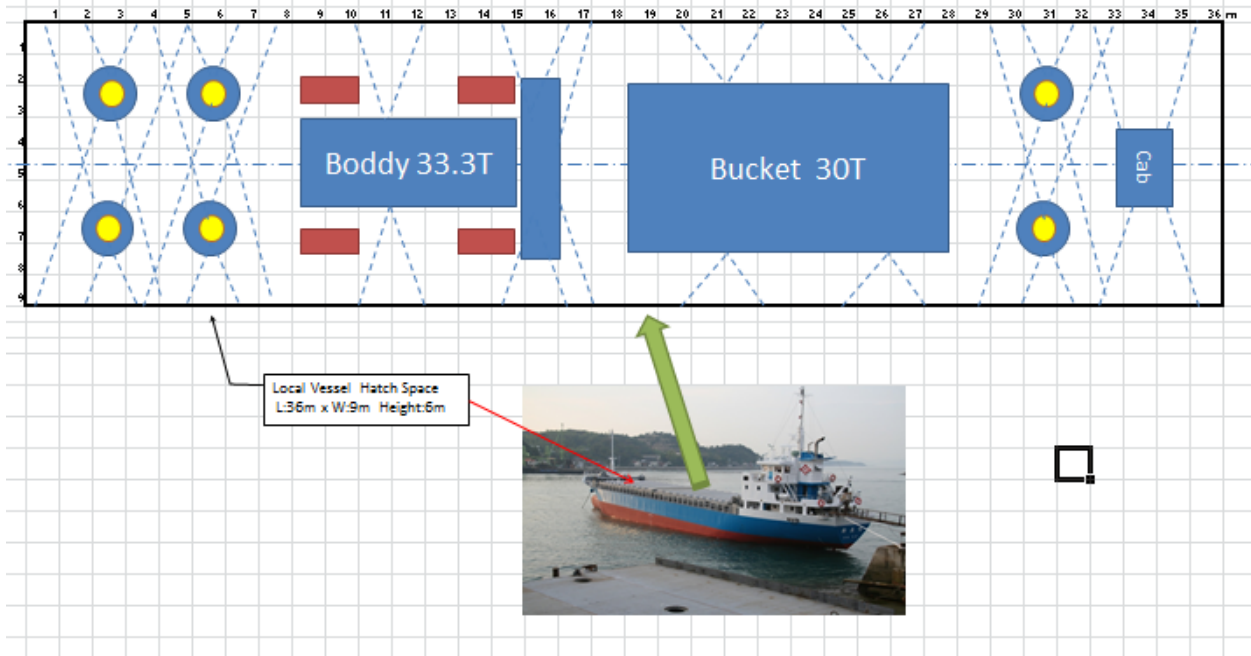

Appendix h

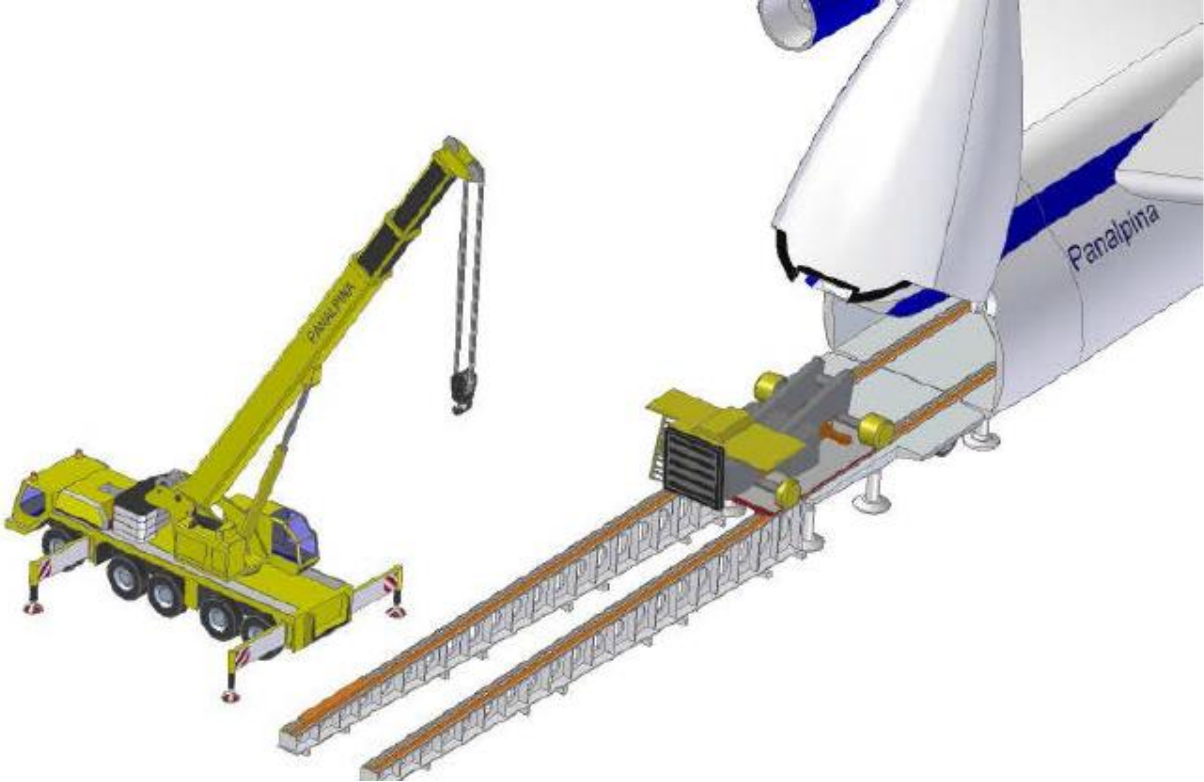

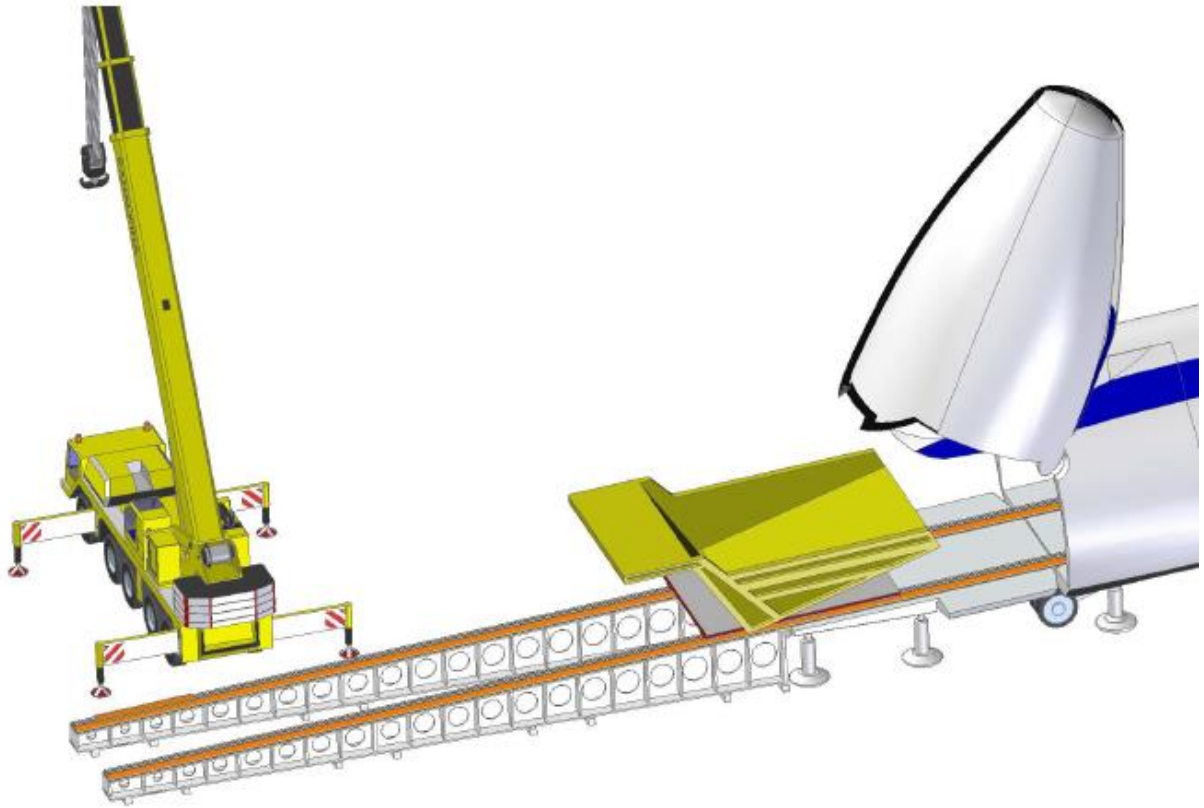

Appendix i

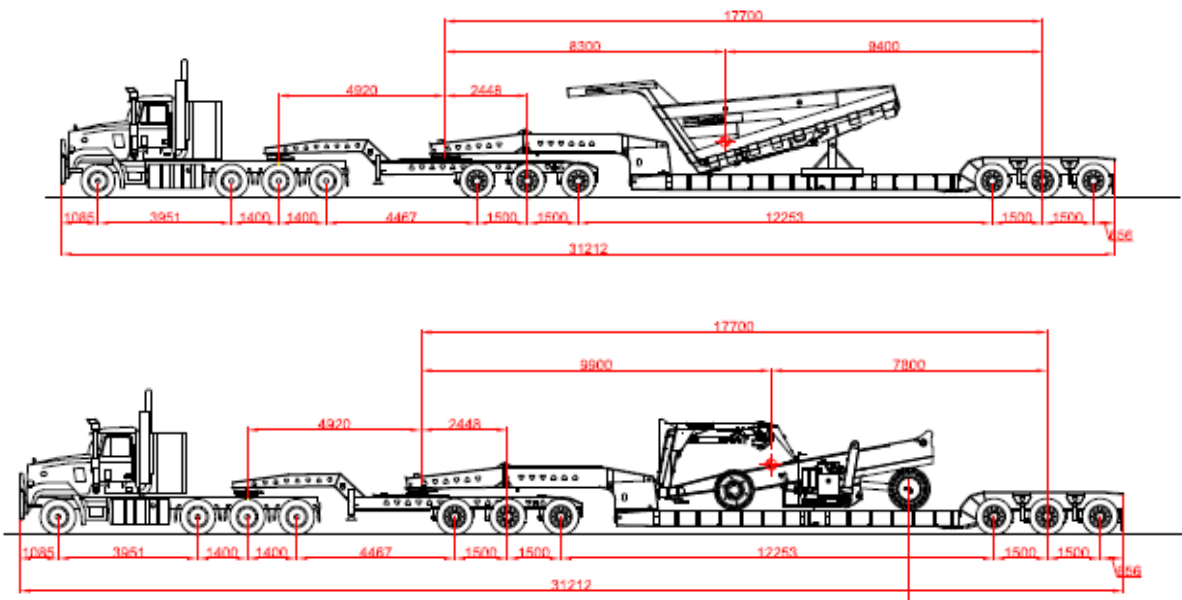

Appendix j



Appendix k



Appendix l

Rail option			Trucking to rail yard		Rail costs including loading	
	destination	# of Buses	per bus	Total cost	Per bus	Total cost
Edmonton to Tacoma	St. Petersburg	20	615	12,300	9,100	182,000
Edmonton to Houston	Novorossiysk	20	615	12,300	10,750	215,000
Edmonton to Baltimore	St. Petersburg	20	615	12,300	11,700	234,000

Trucking option			Trucking to port	
	destination	# of Buses	per bus	Total cost
Edmonton to Tacoma	St. Petersburg	20	3,230	64,600
Edmonton to Houston	Novorossiysk	20	4,200	84,000
Edmonton to Baltimore	St. Petersburg	20	4,400	88,000

Appendix m



Appendix n

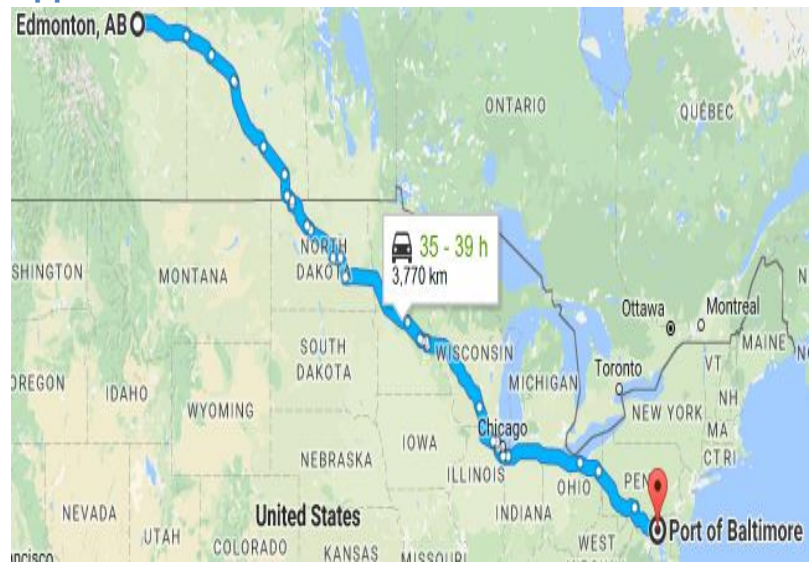



Appendix o



Appendix p

Working instructions



**Höegh Autoliners Heavy Duty
Webb Lash**
Breaking load 10000 kg MSL 5000 kg.

Unit weight (kg)	Total number of lashings
10000 - 20000	4
20000 - 40000	8
40000 - 60000	12
60000 - 80000	16
80000 - 100000	20

NOTE! Minimum number of lashings to be used when securing units on air rubber tyres on dry and clean decks.

Appendix q



The picture above illustrates the reason for the required lashing standard for rolltrailer cargo.

Appendix r

